



(19) **United States**

(12) **Patent Application Publication**  
**Park et al.**

(10) **Pub. No.: US 2010/0156765 A1**  
(43) **Pub. Date: Jun. 24, 2010**

(54) **ORGANIC LIGHT EMITTING DIODE DISPLAY**

(21) Appl. No.: **12/654,362**

(22) Filed: **Dec. 17, 2009**

(75) Inventors: **Soon-Ryong Park**, Yongin-City (KR); **Woo-Sukof Jung**, Yongin-City (KR); **Hee-Chul Jeon**, Yongin-City (KR); **Eun-Ah Kim**, Yongin-City (KR); **Hee-Seong Jeong**, Yongin-City (KR); **Noh-Min Kwak**, Yongin-City (KR); **Chul-Woo Jeong**, Yongin-City (KR); **Joo-Hwa Lee**, Yongin-City (KR)

(30) **Foreign Application Priority Data**

Dec. 23, 2008 (KR) ..... 10-2008-0132374

**Publication Classification**

(51) **Int. Cl.**  
**G09G 3/30** (2006.01)  
**H01J 5/16** (2006.01)

(52) **U.S. Cl.** ..... **345/77; 313/110**

Correspondence Address:  
**ROBERT E. BUSHNELL & LAW FIRM**  
**2029 K STREET NW, SUITE 600**  
**WASHINGTON, DC 20006-1004 (US)**

(57) **ABSTRACT**

An organic light emitting diode (OLED) display includes a substrate where OLEDs are formed and an encapsulation member fixed onto the substrate while covering the OLEDs. The encapsulation member includes a photochromic material so that the encapsulation member is colored by external light.

(73) Assignee: **SAMSUNG MOBILE DISPLAY CO., LTD.**, Yongin-City (KR)

12

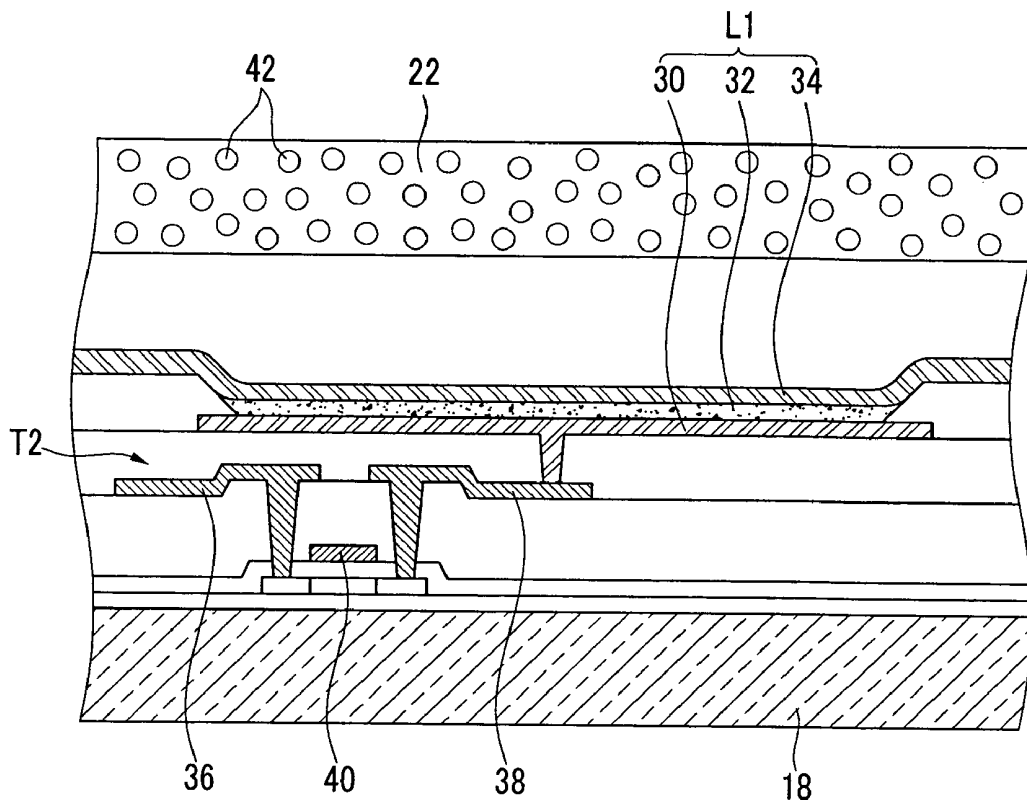

FIG. 1

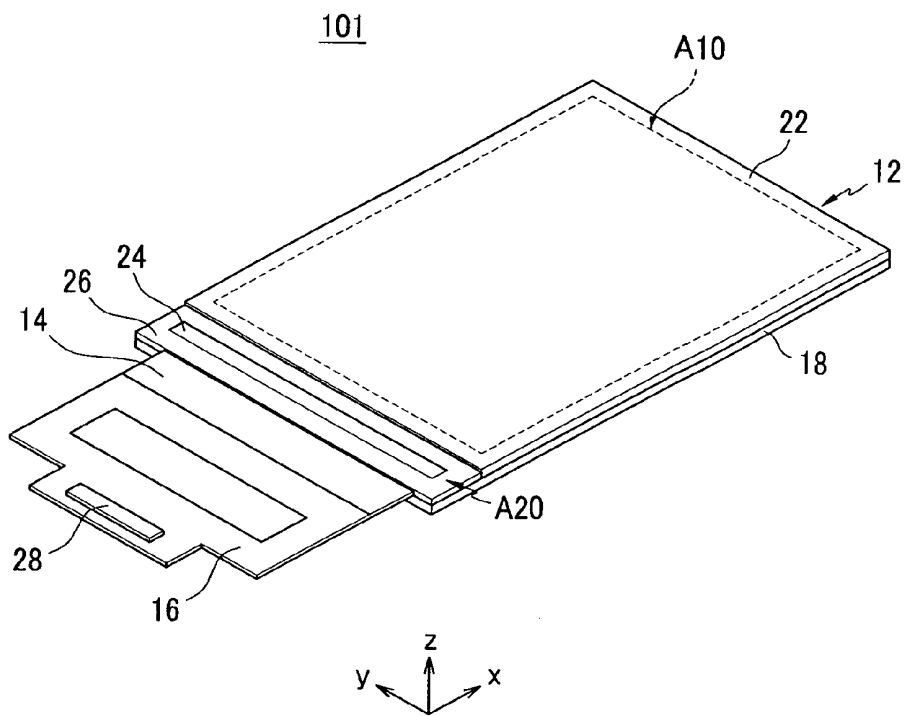

FIG.2

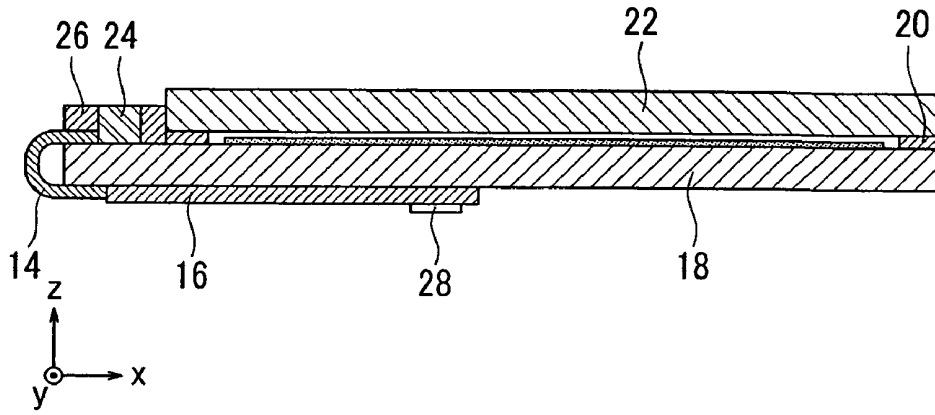

FIG.3

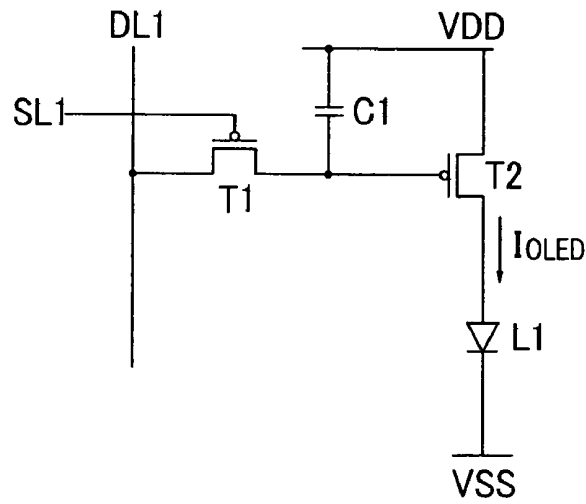

FIG.4

12

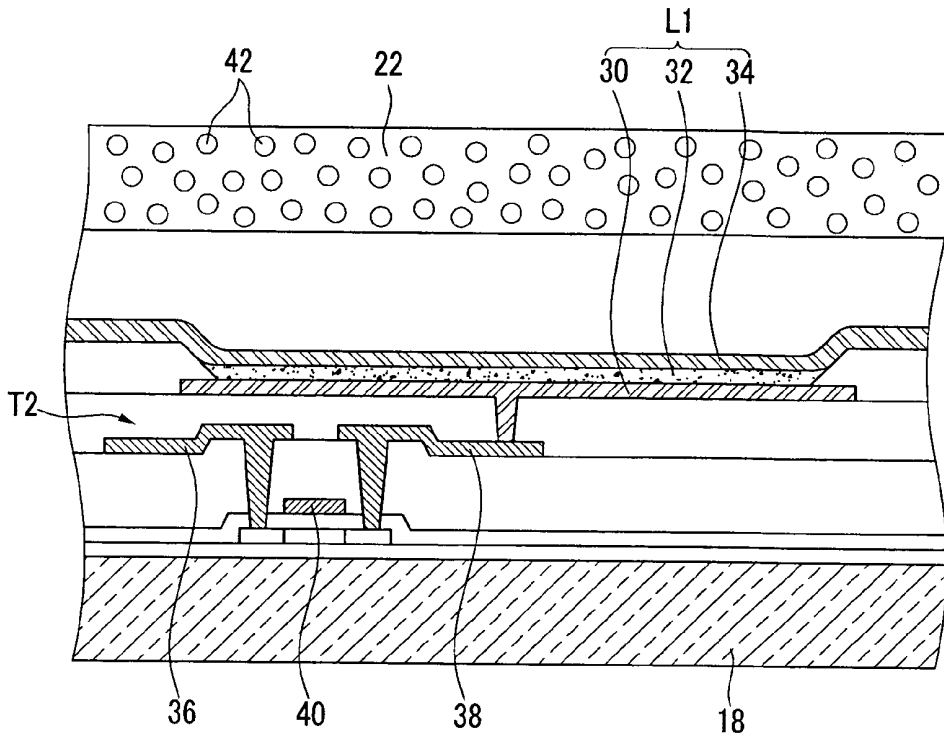

FIG.5

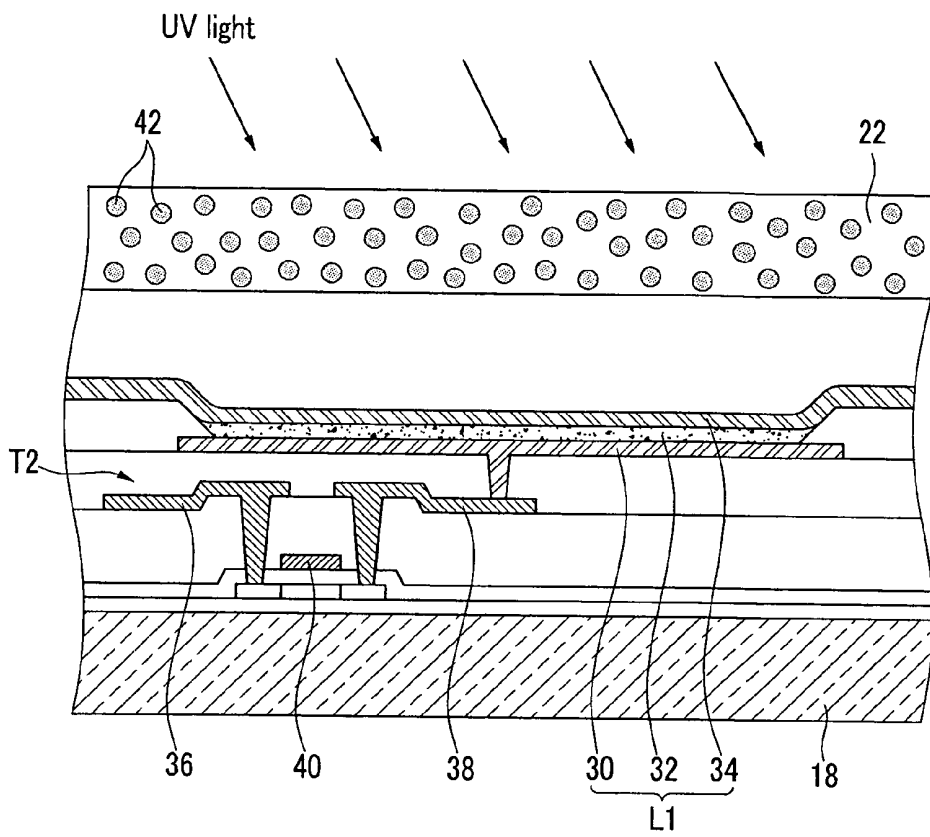

FIG. 6

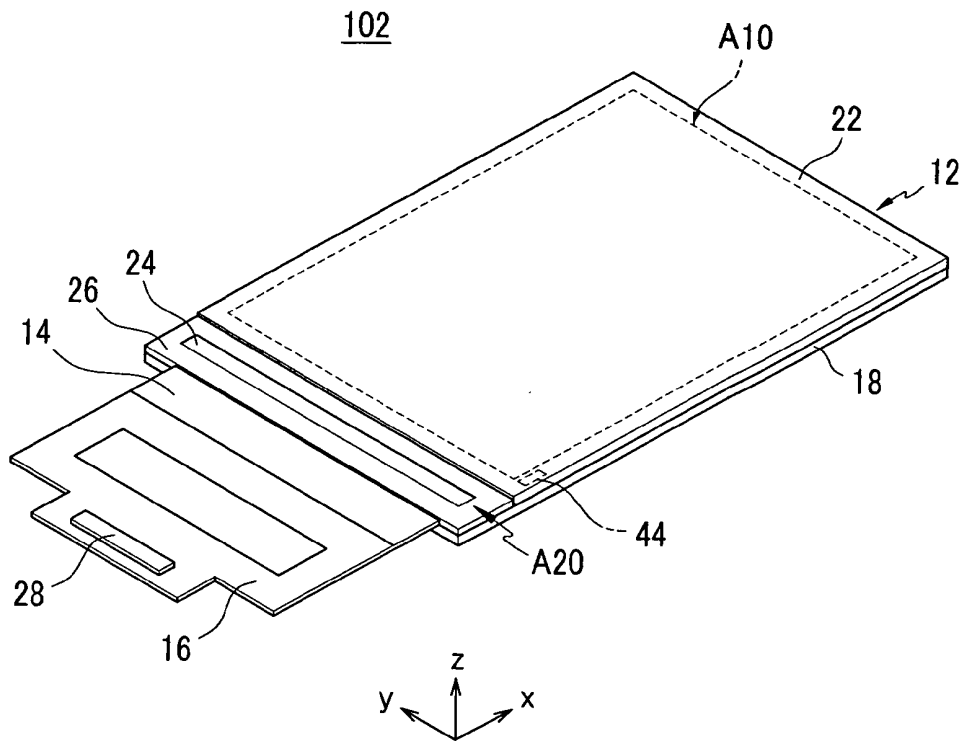
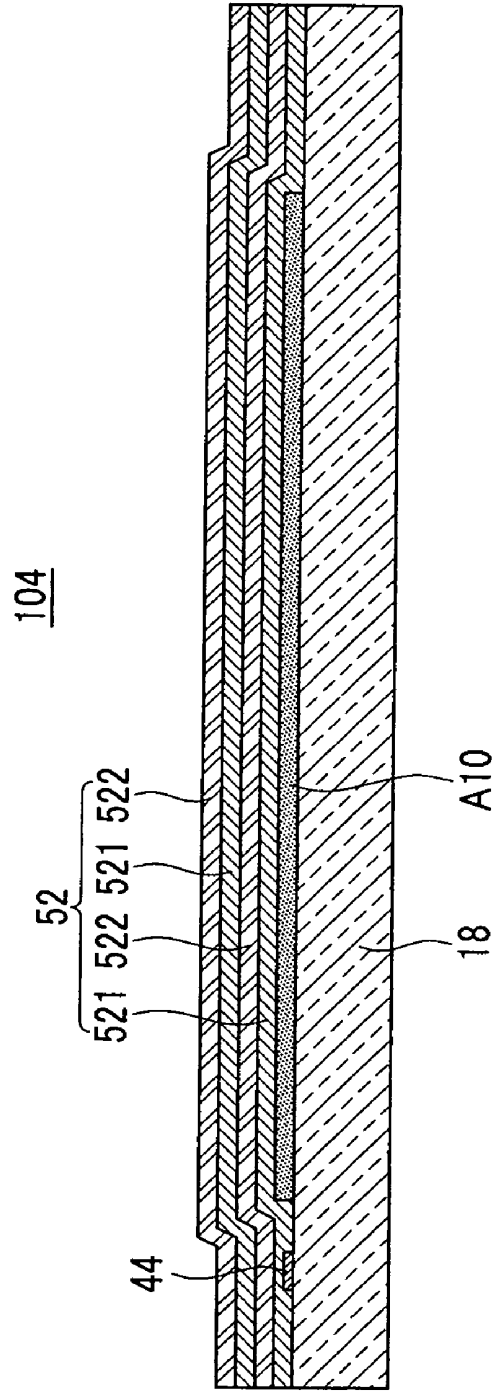



FIG. 9



## ORGANIC LIGHT EMITTING DIODE DISPLAY

### CLAIM OF PRIORITY

**[0001]** This application makes reference to, incorporates into this specification the entire contents of, and claims all benefit accruing under 35 U.S.C. §119 from an application earlier filed in the Korean Intellectual Patent Office on Dec. 23, 2008 and there duly assigned Serial No. 10-2008-0132374.

### BACKGROUND OF THE INVENTION

**[0002]** 1. Field of the Invention

**[0003]** The present invention relates to an organic light emitting diode (OLED) display. More particularly, the present invention relates to an OLED display having improved visibility outdoors by minimizing reflection of external light.

**[0004]** 2. Description of the Related Art

**[0005]** In an organic light emitting diode (OLED) display, display quality is greatly influenced by external light. That is, when external light is transmitted to the OLED display, reflection of the external light occurs in layers that form an organic emission element and a thin film transistor. For example, a metal layer used as an electrode has high light reflectivity so that the metal layer reflects most of the external light. The reflected external light is mixed with the light emitted from an organic emission layer such that visibility of the screen is undesirably deteriorated.

**[0006]** In order to solve the above-stated problem, a linear polarization film and a  $\lambda/4$  phase delay film are disposed in a side where the external light is transmitted in a contemporary OLED display. In this structure, a polarizing axis is changed by 90 degrees when the external light passes through the linear polarization film and the  $\lambda/4$  phase delay film and is then reflected by internal layers, and therefore the external light is absorbed since the external light cannot pass through the linear polarization film. Through this theory, the reflection of the external light can be suppressed to thereby enhance visibility.

**[0007]** In the above-described structure, however, half of the light (non-polarized light) emitted from the organic emission layer is blocked since the light cannot pass through the linear polarization film. Such a light loss undesirably decreases efficiency (luminance/power consumption) of the OLED display.

**[0008]** The above information disclosed in this Background section is only for enhancement of understanding of the background of the invention and therefore it may contain information that does not form the prior art that is already known in this country to a person of ordinary skill in the art.

### SUMMARY OF THE INVENTION

**[0009]** It is therefore an object of the present invention to provide an improved an organic light emitting diode (OLED) display.

**[0010]** It is another object to provide an organic light emitting diode (OLED) display having an advantage of enhancing visibility by minimizing reflection of external

**[0011]** light while maintaining high efficiency.

**[0012]** These and other objects may be attained in the practice of the principles of the present invention, with an OLED display constructed with a substrate where OLEDs are

formed and an encapsulation member that is fixed onto the substrate while covering the OLEDs. The encapsulation member includes a photochromic material so that the encapsulation member is colored by external light.

**[0013]** The substrate may be a semiconductor substrate, and the encapsulation member may be an encapsulation substrate. The encapsulation substrate may be formed of glass. The OLED display may further include a photosensor disposed in an overlapped area of the semiconductor substrate and the encapsulation substrate.

**[0014]** The encapsulation member may be a thin film encapsulation layer comprising a plurality of inorganic layers and a plurality of organic layers that are alternately stacked. The farthest layer among the plurality of inorganic layers and the plurality of organic layers from the substrate may include the photochromic material. The OLED display may further include a photosensor disposed between the thin film encapsulation layer and the substrate.

**[0015]** The photochromic material may include one selected from a group of silver halide, zinc halide, cadmium halide, copper halide, and magnesium halide.

**[0016]** The photochromic material may include one selected from a group of spiroyrane, spironaphthoxazine dye, diarylethene derivatives, dehydropyridine, furylfulgide derivatives, and azobenzene derivatives.

### BRIEF DESCRIPTION OF THE DRAWINGS

**[0017]** A more complete appreciation of the invention, and many of the attendant advantages thereof, will be readily apparent as the same becomes better understood by reference to the following detailed description when considered in conjunction with the accompanying drawings in which like reference symbols indicate the same or similar components, wherein:

**[0018]** FIG. 1 is an oblique view of an organic light emitting diode (OLED) display constructed as a first exemplary embodiment according to the principles of the present invention;

**[0019]** FIG. 2 is a cross-sectional view of the OLED display constructed as the first exemplary embodiment according to the principles of the present invention;

**[0020]** FIG. 3 shows a sub-pixel circuit of a panel assembly of FIG. 1;

**[0021]** FIG. 4 and FIG. 5 are partial cross-sectional views of the panel assembly of FIG. 1;

**[0022]** FIG. 6 is an oblique view of an OLED display constructed as a second exemplary embodiment according to the principles of the present invention;

**[0023]** FIG. 7 is a block diagram of the OLED display according to the second exemplary embodiment of the present invention;

**[0024]** FIG. 8 is a partial enlarged cross-sectional view of an OLED display constructed as a third exemplary embodiment according to the principles of the present invention; and

**[0025]** FIG. 9 is a cross-sectional view of an OLED display constructed as a fourth exemplary embodiment according to the principles of the present invention.

### DETAILED DESCRIPTION OF THE EMBODIMENTS

**[0026]** The present invention will be described more fully hereinafter with reference to the accompanying drawings, in which exemplary embodiments of the invention are shown.

[0027] As those skilled in the art would realize, the described embodiments may be modified in various different ways, all without departing from the spirit or scope of the present invention.

[0028] FIG. 1 and FIG. 2 respectively show an oblique view and a cross-sectional view of an organic light emitting diode (OLED) display constructed as a first exemplary embodiment according to the principles of the present invention.

[0029] Referring to FIG. 1 and FIG. 2, an OLED display 101 according to the first exemplary embodiment includes a panel assembly 12 having a display area A10 and a pad area A20 and displaying a predetermined video and visual image in display area A10, a flexible circuit board 14 fixed to pad area A20, and a printed circuit board 16 electrically connected to panel assembly 12 through flexible circuit board 14.

[0030] Panel assembly 12 includes a first substrate (or, a semiconductor substrate) 18 and a second substrate (or, an encapsulation substrate) 22 that is smaller than first substrate 18 and having an edge fixed to first substrate 18 by a sealant 20 (refer to FIG. 2). Display area A10 is located in an area where first substrate 18 and

[0031] second substrate 20 are overlapped at an interior side of sealant 20, and pad area A20 is located on first substrate 18 at an external side of sealant 20.

[0032] A plurality of subpixels are disposed in a matrix pattern in display region A10 of first substrate 18, and a scan driver (not shown) and a data driver (not

[0033] shown) are located between display area A10 and sealant 20 or at the external side of sealant 20 for driving the subpixels. In pad area A20 of first substrate 18, pad electrodes (not shown) for transmitting electrical signals to the scan and data drivers are located.

[0034] An integrated circuit chip 24 is mounted on pad area A20 of first substrate 18, and flexible circuit board 14 is electrically connected to the pad electrodes and integrated circuit chip 24. A protective layer 26 is formed around integrated circuit chip 24 and flexible circuit board 14 to cover the pad electrodes formed in pad area A20 for protection. In flexible circuit board 16, electronic components are provided for processing driving signals, and a connector 28 is provided for transmitting external signals to flexible circuit board 16.

[0035] In a rear side of panel assembly 12, a bezel (not shown) for increasing bending strength of panel assembly 12 or a buffering tape (not shown) for increasing impact resistance of panel assembly 12 may be formed. Flexible circuit board 14 fixed to pad area A20 is bent to the rear side of panel assembly 12 to make flexible circuit board 16 face the rear side of panel assembly 12.

[0036] FIG. 3 shows a structure of a sub-pixel of the panel assembly of FIG. 1,

[0037] and FIG. 4 is a partial enlarged cross-sectional view of the panel assembly of FIG. 1.

[0038] Referring to FIG. 3 and FIG. 4, a sub-pixel of panel assembly 12 is formed of an OLED L1 and a driving circuit unit. OLED L1 includes an anode (hole injection electrode) 30, an organic emission layer 32, and a cathode (electron injection electrode) 34, and the driving circuit unit includes at least two thin film transistors T1

[0039] and T2 and at least one storage capacitor C1. The two thin film transistors T1 and T2 are a switching transistor T1 and a driving transistor T2, respectively.

[0040] Switching transistor T1 is connected to a scan line SL1 and a data line DL1, and transmits a data voltage input to data line DL1 according to a switching voltage that is input to

scan line SL1 to driving transistor T2. Storage capacitor C1 is connected to switching transistor T1 and power source line VDD, and stores a voltage that corresponds to a voltage difference between a voltage transmitted from switching transistor T1 and a voltage supplied to power source line VDD.

[0041] Driving transistor T2 is connected to power source line VDD and storage capacitor C1, and supplies an output current  $I_{OLED}$  that is proportional to the square of the difference between the voltage stored in storage capacitor C1 and a threshold voltage to OLED L1. OLED L1 emits light by output current  $I_{OLED}$ . Driving transistor T2 includes a source electrode 36, a drain electrode 38, and a gate electrode 40, and anode 30 of OLED L1 may be connected to drain electrode 38 of driving transistor T2. The configuration of the sub-pixel is not limited thereto, and may be variously modified.

[0042] In OLED L1, anode 30 is formed of a metal layer having a light reflection characteristic, and cathode 34 is formed of a transparent conductive layer. Therefore, light emitted from organic emission layer 32 passes through cathode 34 and second substrate 22 and is emitted out. Anode 30 reflects the light emitted toward first substrate 18 along with the light emitted from organic emission layer 32 to second substrate 22 to thereby enhance luminous efficiency. Second substrate 22 is an

[0043] encapsulation member that covers OLEDs L1 for protection, and is made of glass.

[0044] In the first exemplary embodiment, a substrate on which external light is incident, that is, second substrate 22, includes a photochromic material which is an ultraviolet (UV) discoloration material. Second substrate 22 including the photochromic material has a characteristic that displays a color when UV light illuminates second substrate 22 and returns to a transparent state when the UV light does not illuminate second substrate 22. The photochromic material is mixed with glass during a manufacturing process of second substrate 22 and uniformly dispersed inside second substrate 22. In FIG. 4, photochromic material 42 is schematically illustrated as round particles.

[0045] Any well-known photochromic material can be used as photochromic material 42. For example, photochromic material 42 may be selected from a group consisting of silver halide, zinc halide, cadmium halide, copper halide, and magnesium halide. Alternatively, photochromic material 42 may be selected from a group consisting of spiropyrane, spironaphthoxazine dye, diarylethene derivatives, dehydro-pyridine, furylfulgide derivatives, and azobenzene derivatives. Photochromic material 42 included in second substrate 22 is not, however, limited thereto.

[0046] As described, second substrate 22 including photochromic material 42 has high light transmittance because second substrate 22 becomes colorless upon exposure to weak sunlight, for example in a normal indoor environment. In addition, under a strong sunlight condition, second substrate 22 becomes colored by photochromic material 42 and absorbs external light. That is, in the case that an

[0047] electron device using OLED display 101 is observed outdoors during the daytime, second substrate 22 becomes colored (refer to FIG. 5).

[0048] Therefore, OLED display 101 according to the first exemplary embodiment of the principles of the present invention can increase visibility of the screen by reducing reflection of external light under a strong sunlight condition. In this case, transmittance of light emitted from organic emission layer 32 is reduced due to coloration of second substrate 22,

but the amount of the reduced transmittance of light is less than that in a case in which a linear polarization film and a  $\lambda/4$  phase delay film are applied, instead of the photochromic material, on OLEDs L1. Accordingly, efficiency (luminance/power consumption) of OLED display 101 can be improved.

[0049] FIG. 6 is an oblique view of an OLED display constructed a second exemplary embodiment according to the principles of the present invention.

[0050] Referring to FIG. 6, an OLED display 102 according to the second exemplary embodiment is the same as the OLED display of the first exemplary embodiment, except that a photosensor 44 is formed inside a panel assembly 12. Like reference numerals are used for like elements of the first exemplary embodiment.

[0051] Photosensor 44 is disposed on a portion of first substrate 18 which overlaps second substrate 22. Photosensor 44 may be disposed between sub-pixels in display area A10, or may be disposed between display area A10 and a sealant 20 (refer to FIG. 2). FIG. 6 illustrates a case in which photosensor 44 is exemplarily disposed at an external side of display area A10. Photosensor 44 detects the amount of light passing through second substrate 22 in order to increase the light emission intensity of organic emission layer 32 (refer to FIG. 4) when second substrate 22 is colored.

[0052] FIG. 7 is a block diagram of the OLED display according to the second exemplary embodiment of the principles of the present invention. Referring to FIG. 7, OLED display 102 includes photosensor 44, an analog to digital (A/D) converter 46, a data driver 48, and a panel assembly 12 where display area A10 is formed.

[0053] Photosensor 44 is formed of various types of sensors that can detect the amount of surrounding light. For example, photosensor 44 may be formed of one of a photodiode, a charge-coupled element, a charge injection element, a photomultiplier tube, a spectroradiometer, and a complementary metal-oxide semi-conductor (CMOS) photoelectric element. Photosensor 44 outputs a voltage signal or a current signal corresponding to the amount of light passing through second substrate 22. In this case, a coloration degree of second substrate 22 is increased as the strength of the external light is increased, and photosensor 44 can detect a small amount of external light.

[0054] A/D converter 46 receives a voltage or a current output from photosensor 44 as an analog signal and converts the analog signal into a digital signal. By using the digital signal provided from A/D converter 46, data driver 48 provides a data voltage that appropriately corresponds to the coloration degree of second substrate 22 to panel assembly 12. The data voltage output from data driver 48 is formed of individual data voltages representing red, green, and blue. For this, data driver 48 includes a gamma controller 50.

[0055] Gamma controller 50 includes a plurality of gamma curves that respectively correspond to the coloration degree of second substrate 22, detected by photosensor 44. Data driver 48 can control the data voltage provide to panel assembly 12 by using a data voltage setting value stored in gamma controller 50.

[0056] By the above-described configuration, OLED display 102 according to the second exemplary embodiment can enhance visibility and contrast ratio of the display by increasing light emission intensity of organic emission layer 30 (refer to FIG. 4) as the coloration degree of second substrate 22 is increased.

[0057] FIG. 8 is a partial enlarged cross-sectional view of an OLED display constructed as a third exemplary embodiment according to the principle of the present invention.

[0058] Referring to FIG. 8, an OLED display 103 according to the third exemplary embodiment is the same as the OLED display of the first exemplary embodiment except that a thin film encapsulation layer 52 is provided as an encapsulation member instead of the second substrate of the first exemplary embodiment. Like reference numerals are used for like elements of the first exemplary embodiment.

[0059] Thin film encapsulation layer 52 is formed of two or more inorganic layers 521 and two or more organic layers 522. Inorganic layers 521 and organic layers 522 are alternately stacked. FIG. 8 illustrates a case in which thin film encapsulation layer 52 is formed by alternately stacking each of two inorganic layers 521 and each of two organic layers 522.

[0060] Inorganic layer 521 may be formed of aluminum oxide or silicon oxide, and organic layer 522 may be formed of any one of epoxy, acrylate, and urethane acrylate. Inorganic layer 521 suppresses penetration of external moisture and oxygen, and organic layer 522 eases internal stress of inorganic layer 521 or fills micro-cracks and pinholes of inorganic layer 521.

[0061] Among the plurality of layers that form thin film encapsulation layer 52, at least one layer includes a photochromic material 42 so that thin film encapsulation layer 52 is colored by external light. When at least one inorganic layer 521 includes photochromic material 42, photochromic material 42 is mixed with an inorganic layer forming material during the inorganic layer forming process so that photochromic material 42 can be uniformly dispersed inside inorganic layer 521. When at least one organic layer 522 includes photochromic material 42, photochromic material 42 is mixed with an organic layer forming material during the organic layer forming process so that photochromic material 42 can be uniformly dispersed inside organic layer 522.

[0062] The uppermost layer (the farthestmost layer from first substrate 18) among the plurality of layers forming thin film encapsulation layer 52 may include photochromic material 42. In this case, reflection of external light by the layers forming encapsulation layer 52 can be minimized. FIG. 8 illustrates a case in which photochromic material 42 is included in the uppermost organic layer 522 of thin film encapsulation layer 522.

[0063] FIG. 9 is a cross-sectional view of an OLED display constructed as a fourth exemplary embodiment according to the principles of the present invention.

[0064] Referring to FIG. 9, an OLED display 104 according to the fourth exemplary embodiment is the same as the OLED display of the third exemplary embodiment except that a photosensor 44 is provided in a lower portion of a thin film encapsulation layer 52. Like reference numerals are used for like elements of the first exemplary embodiment.

[0065] Photosensor 44 is disposed on a portion of a first substrate 18 which

[0066] overlaps thin film encapsulation layer 52. Photosensor 44 may be disposed between sub-pixels in a display area A10, or may be disposed at an external side of display area A10. FIG. 9 illustrates a case in which photosensor 44 is exemplarily disposed at the external side of display area A10.

[0067] Photosensor 44 detects the amount of light passing through thin film encapsulation layer 52 in order to increase light emission intensity of an organic emission layer 32 (refer

to FIG. 8) when thin film encapsulation layer 52 is colored. Photosensor 44 is connected to an A/D converter and a data driver, and configurations and functions of photosensor 44, the A/D converter, the data driver, and a gamma controller are the same as those of the OLED display of the second exemplary embodiment.

[0068] While this invention has been described in connection with what is presently considered to be practical exemplary embodiments, it is to be understood that the invention is not limited to the disclosed embodiments, but, on the contrary, is intended to cover various modifications and equivalent arrangements included within the spirit and scope of the appended claims.

What is claimed is:

1. An organic light emitting diode (OLED) display, comprising:

a substrate where OLEDs are formed; and  
an encapsulation member that is fixed onto the substrate while covering the OLEDs,  
wherein the encapsulation member includes a photochromic material so that the encapsulation member is colored by external light.

2. The OLED display of claim 1, wherein the substrate is a semiconductor substrate, and the encapsulation member is an encapsulation substrate.

3. The OLED display of claim 2, wherein the encapsulation substrate is formed of glass.

4. The OLED display of claim 2, further comprising a photosensor disposed in an overlapped area of the semiconductor substrate and the encapsulation substrate.

5. The OLED display of claim 1, wherein the encapsulation member is a thin film encapsulation layer comprising a plurality of inorganic layers and a plurality of organic layers that are alternately stacked.

6. The OLED display of claim 5, wherein at least one of the plurality of inorganic layers and the plurality of organic layers comprises the photochromic material.

7. The OLED display of claim 5, wherein the farthest layer among the plurality of inorganic layers and the plurality of organic layers from the substrate includes the photochromic material.

8. The OLED display of claim 5, wherein the inorganic layer is formed of one selected from a group of aluminum oxide or silicon oxide, and the organic layer is formed of one selected from a group of epoxy, acrylate, and urethane acrylate.

9. The OLED display of claim 5, further comprising a photosensor disposed between the thin film encapsulation layer and the substrate.

10. The OLED display of claim 1, wherein the photochromic material comprises one selected from a group of silver halide, zinc halide, cadmium halide, copper halide, and magnesium halide.

11. The OLED display of claim 1, wherein the photochromic material comprises one selected from a group of spiro-pyrane, spironaphthoxazine dye, diarylethene derivatives, dehydropyridine, furylfulgide derivatives, and azobenzene derivatives.

12. The OLED display of claim 1, further comprising a photosensor disposed in an area where the substrate and the encapsulation member are overlapped.

13. The OLED display of claim 12, further comprising:

an analog to digital (A/D) converter receiving an analog signal output from the photosensor, and converting the analog signal into a digital signal;

a data driver receiving the digital signal output from the analog to digital converter, and providing a data voltage that corresponds to a coloration degree of the encapsulation member.

14. The OLED display of claim 13, wherein the data driver further comprises a gamma controller.

\* \* \* \* \*

专利名称(译)	有机发光二极管显示器		
公开(公告)号	<a href="#">US20100156765A1</a>	公开(公告)日	2010-06-24
申请号	US12/654362	申请日	2009-12-17
[标]申请(专利权)人(译)	三星显示有限公司		
申请(专利权)人(译)	三星移动显示器有限公司.		
当前申请(专利权)人(译)	三星移动显示器有限公司.		
[标]发明人	PARK SOON RYONG JUNG WOO SUKOF JEON HEE CHUL KIM EUN AH JEONG HEE SEONG KWAK NOH MIN JEONG CHUL WOO LEE JOO HWA		
发明人	PARK, SOON-RYONG JUNG, WOO-SUKOF JEON, HEE-CHUL KIM, EUN-AH JEONG, HEE-SEONG KWAK, NOH-MIN JEONG, CHUL-WOO LEE, JOO-HWA		
IPC分类号	G09G3/30 H01J5/16		
CPC分类号	G02B5/23 H01L27/3232 H01L51/5284 H01L51/524 H01L27/3269 H01L31/02366 H01L51/5246 H01L2924/062 G09G3/3291 G09G2310/027 G09G2320/0233 G09G2360/148 G09G2380/02		
优先权	1020080132374 2008-12-23 KR		
外部链接	<a href="#">Espacenet</a> <a href="#">USPTO</a>		

摘要(译)

有机发光二极管 ( OLED ) 显示器包括其中形成OLED的基板和固定到基板上同时覆盖OLED的封装构件。封装构件包括光致变色材料，使得封装构件通过外部光着色。

